



BC / BL / BLR 2604

V1.9

© Baracoda™ - October 2003

Baracoda, Inc. (US Office)
45 Main street - Suite 616 - Brooklyn, NY 11201
Ph: 718 488 9600 - Fx: 718 488 9601

Baracoda SA (Europe Office: France)
30 Avenue de l'Amiral Lemonnier - 78160 Marly-Le-Roi
Ph: +33 1 30 08 89 00 - Fx: +33 1 30 08 89 98



The bluetooth name and Bluetooth registered trademarks are owned by Bluetooth SIG, Inc., and are used by Baracoda under license. The Baracoda names and Baracoda trademarks are own by Baracoda. All specification are subject to change without notice - Non contractual pictures © Baracoda - All rights reserved

SUMMARY

SUMMARY	1
INTRODUCTION	2
Protocol of communication	3
1. Between the REMOTE APLICACION and the SmartModule	3
1.1. Format of packet	3
1.2. Remote application to the SmartModule	3
1.2.1. Commands	3
1.2.2. Details of commands	4
1.2.3. Specials commands	8
1.3. SmartModule to the remote application.....	9
1.3.1. Events	9
1.3.2. Details of events.....	9
2. Between the REMOTE APLICACION and the MPU.....	13
2.1. Format of packet	13
2.1.1. Single command	13
2.2. Remote application to the MPU.....	13
2.2.1. “General” commands.....	13
2.2.2. Details of “General” commands	13
2.2.3. Commands to configure Symbologies.....	15
2.3. MPU to remote application	20
2.3.1. “Normal” events.....	20
2.3.2. “General” commands events	20
2.3.3. “Symbologies” commands event.....	20
3. DETAILS OF A SENDING OF BARCODES	25
3.1. Possibilities.....	25
3.2. Management of acknowledgment	25
3.2.1. Barcode ACK command format	26
3.2.2. Examples.....	26
4. DEFAULT SETTINGS.....	27
4.1. Smartmodule	27
4.2. Decoder	28

INTRODUCTION

This document aims to detail all the protocol of communication between each entity of the Baracoda Scanner 2604.

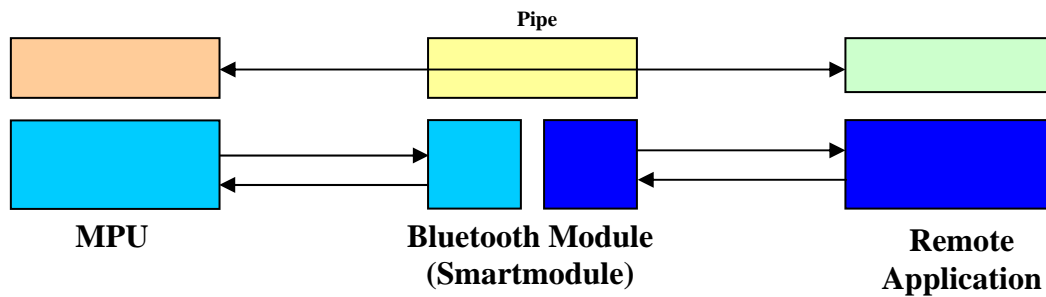

By default the Bluetooth Module forwards all data to the MPU (pipe mode). In order to configure the SmartModule, you need to break the pipe by sending the command:

0x01	0x01	0x01
------	------	------

3 bytes

Then to reestablish the pipe, you must send the command:

0x01	0x02	0x01
------	------	------

3 bytes

Protocol of communication

1. Between the REMOTE APLICACION and the SmartModule

1.1.Format of packet

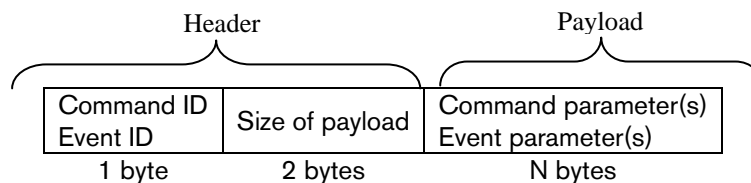

Before sending SmartModule commands, do not forget to break the pipe by sending the command "0x01 0x01 0x01".

1.2.Remote application to the SmartModule

1.2.1. Commands

Command ID	Size (bytes)	Name	Return
0x01	N • 16	Set Pin Code	Ack (see description below)
0x07	0	Get Pin Code	Pin_Code
0x02	N • 248	Set Name	Ack (see description below)
0x08	0	Get Name	Name
0x03	1	Set Mode	Ack (see description below)
0x04	0	Get Mode	Mode
0x09	4	Set Sniff	Ack (see description below)
0x10	0	Get Sniff	Sniff
0x21	N • 17	Set Security Mode	Ack (see description below)
0x20	0	Get Security Mode	Security_Mode
0x19	2	Set Link Time Out	Ack (see description below)
0x18	0	Get Link Time Out	Link_Tmo
0x05	6	Set Remote BDA	Ack (see description below)
0x06	0	Get Remote BDA	Remote_BDA
0x14	4	Set PageScan	Ack (see description below)
0x13	0	Get PageScan	PageScan
0x16	4	Set InquiryScan	Ack (see description below)
0x15	0	Get Inquiry Scan	InquiryScan
0x38	4	Set Power	Ack (see description below)
0x39	0	Get Power	Power
0x32	4	Set Timers	Ack (see description below)
0x33	0	Get Timers	Timers
0x34	N • 41	Set Prefix/Suffix	Ack (see description below)
0x35	0	Get Prefix/Suffix	Prefix/Suffix
0x36	3	Set SendingFormat	Ack (see description below)
0x37	0	Get SendingFormat	Sending Format

0x76	0	Get Versions	Versions
------	---	--------------	----------

Specials commands:

Command	Name	Return
0x52 0x73 0x74	Reset	None

Description of the ack event:

Command ID	Size	Result
Command ID	0x0001	0x00 → Set command successful 0x01 → Set command failed

1.2.2. Details of commands

- Set Pin Code

This command is used to change the pin code that is used to create a connection when the authentication is enabled.

Command	header		Command parameter(s)	Return parameter(s)
	ID	Size		
Set Pin Code	0x01	N	Pin code	Ack

Parameter	Size	Parameter description
Pin code	N bytes	New pin code (N • 16)

- Set Name

This command is used to change the name of the device (by default: Baracoda2604).

Command	header		Command parameter(s)	Return parameter(s)
	ID	Size		
Set Name	0x02	N	Name	Ack

Parameter	Size	Parameter description
Name	N bytes	New name (N • 248)

- Set Mode

This command is used to change the operating mode of the device.

Command	header		Command parameter(s)	Return parameter(s)
	ID	Size		
Set Mode	0x03	0x0001	Mode	Ack

Parameter	Size	Parameter description
Mode	1 byte	0x01 → Batch 0x02 → RealTime 0x03 → Lan (default mode) 0x04 → AutoSwitch

- Lan: all barcodes are transmitted to the remote application. If no connection, barcodes are lost.
- Batch: all barcodes are stored in memory. The remote application must send an "Upload" command to recover them later.
- RealTime: all barcodes are transmitted to the remote application. If there is no connection, the scanner tries to establish a connection with the device stored in memory (see Set Remote BDA). If it failed, scanned barcodes are lost.
- AutoSwitch: all barcodes are transmitted to the remote application. If there is no connection, the scanner tries to establish a connection with the device stored in memory (see Set Remote BDA). If it failed, the scanner goes in batch mode.

- Set Sniff

This command is used to configure the sniff mode (a low power mode). Higher is the latency, longer is the autonomy. Higher is the latency, slower is the response.

Command	header		Command parameter(s)	Return parameter(s)
	ID	Size		
Set Sniff	0x09	0x0004	MinSniff, MaxSniff	Ack

Parameter	Size	Parameter description
MinSniff	2 bytes	Minimum interval, in slots, for sniff mode negotiation
MaxSniff	2 bytes	Maximum interval, in slots, for sniff mode negotiation

Note: $MinSniff \cdot MaxSniff$
 Range: 0x0012 – 0xFFFF (if N= 0, sniff mode is disabled)

- Set Security Mode

This command is used to change the level of security of the Bluetooth connection.

Command	header		Command parameter(s)	Return parameter(s)
	ID	Size		
Set Security Mode	0x21	N	Security mode, pin code	Ack

Parameter	Size	Parameter description
Security mode	1 byte	0x00 → pin code disabled 0x01 → pin code enabled
Pin code	N - 1 bytes	Pin code (N - 1 • 16)

To disable the security, the pin code parameter is not used.

0x21	0x0001	0x00
------	--------	------

But to activate the security, the pin code must be entered in order to authenticate the user.

0x21	0x0005	0x00	0x30 0x30 0x30 0x30
ID	Size	Mode	Pin code

- Set Link Time Out

This timer is used to know if the connection is active or not. If there is no response from the remote device before the end of this timer, it means that the connection is lost.

Command	header		Command parameter(s)	Return parameter(s)
	ID	Size		
Set Link TMO	0x19	0x0002	Nb slots	Ack

Parameter	Size	Parameter description
Nb slots	2 bytes	Number of slots before a link time out

- Set Remote BDA

This command is used to configure a remote device. When the device is master, the scanner creates a connection to this BD@.

Command	header		Command parameter(s)	Return parameter(s)
	ID	Size		
Set Remote BDA	0x05	0x0006	Bd_Addr	Ack

Parameter	Size	Parameter description
Bd_Addr	6 bytes	Remote BDA used in master mode

- Set PageScan

This command is used to change the delay in which the Bluetooth module is discoverable.

Command	header		Command parameter(s)	Return parameter(s)
	ID	Size		
Set PageScan	0x14	0x0004	Ps_Interval, Ps_Window	Ack

Parameter	Size	Parameter description
Ps_Interval	2 bytes	Page scan interval (between 0x0012 and 0x1000 slots)
Ps_Window	2 bytes	Page scan window (between 0x0012 and 0x1000 slots)

- Set InquiryScan

This command is used to change the delay in which the Bluetooth module tries to find other Bluetooth devices.

Command	header		Command parameter(s)	Return parameter(s)
	ID	Size		
Set InquiryScan	0x16	0x0004	Is_Interval, Is_Window	Ack

Parameter	Size	Parameter description
Is_Interval	2 bytes	Inquiry scan interval (between 0x0012 and 0x1000 slots)

Is_Window	2 bytes	Inquiry scan window (between 0x0012 and 0x1000 slots)
-----------	---------	---

- Set Power

This command is used to configure the transmit power.

Command	header		Command parameter(s)	Return parameter(s)
	ID	Size		
Set Power	0x38	0x0004	Def_Power, Max_Power	Ack

Parameter	Size	Parameter description
Def_Power	2 bytes	Default transmit power (in dBm)
Max_Power	2 bytes	Maximum transmit power (in dBm)

- Set Timers

This command is used to configure the shutdown timers.

Command	header		Command parameter(s)	Return parameter(s)
	ID	Size		
Set Timers	0x32	0x0004	Tlisten, Tconnect	Ack

Parameter	Size	Parameter description
Tlisten	2 bytes	Timer used to shutdown the barcode reader when this later is not connected (resolution: second)
Tconnect	2 bytes	Timer used to shutdown the barcode reader when this later is connected (resolution: minute)

- Set Prefix / Suffix

This command is used to configure a prefix and/or a suffix.

Command	header		Command parameter(s)	Return parameter(s)
	ID	Size		
Set Prefix / Suffix	0x34	N • 41	Prefix's length, Prefix, Suffix	Ack

Parameter	Size	Parameter description
Prefix's length	1 byte	Size of the prefix parameter {M byte(s)}
Prefix	M byte	Prefix character(s) (max: 20 characters)
Suffix	N - M - 1 bytes	Suffix character(s) (max: 20 characters)

Note:

If the prefix's size = 0, only a suffix is configured.
 If N = (prefix's size - 1), only a prefix is configured.

To configure a prefix or/and a suffix, the hexadecimal value of a character must be sent in decimal. For example:

Prefix = 'A' (0x41) & Suffix = 'X' (0x58)

Command ID	Size	Prefix's size	Prefix		Suffix	
0x34	0x0005	0x01	0x34 '4'	0x31 '1'	0x35 '5'	0x38 '8'

- Set Sending Format

This command is used to configure the format of transmission of barcodes (see 2.4 Sending of barcodes)

Command	header		Command parameter(s)	Return parameter(s)
	ID	Size		
Set Sending Format	0x36	0x0003	Ack, Prefix/Suffix mode, Baracoda encapsulation	Ack

Parameter	Size	Parameter description
Ack	1 byte	0x00 → ack disable 0x01 → ack enable
Prefix/Suffix mode	1 byte	Add a prefix or/and a suffix 0x00 → disable 0x01 → enable
Encapsulation mode	1 byte	Baracoda encapsulation mode 0x00 → disable 0x01 → enable

1.2.3. Specials commands

- Reset

Command	Packet			Return parameter(s)
Reset	0x52 'R'	0x73 's'	0x74 't'	None

Restore the factory settings :

- See § 4.1. Smartmodule
- Note that is the name of the Bluetooth device isn't changed.

1.3. SmartModule to the remote application

1.3.1. Events

Event ID	Size (bytes)	Name
0x07	N • 16	Pin_Code
0x08	N • 248	Name
0x04	1	Mode
0x10	4	Sniff
0x20	1	Security_Mode
0x18	2	Link_Tmo
0x06	6	Remote_BDA
0x13	4	PageScan
0x15	4	InquiryScan
0x39	4	Power
0x33	4	Timers
0x35	N • 41	Prefix / Suffix
0x37	3	Sending Format
0x76	N	Versions

1.3.2. Details of events

- Pin Code

Event	header		Event parameter(s)
	ID	Size	
Set Pin Code	0x07	N	Pin code

Parameter	Size	Parameter description	Default value
Pin code	N bytes	Pin code (N • 16)	'0000'

- Name

Event	header		Event parameter(s)
	ID	Size	
Name	0x08	N	Name

Parameter	Size	Parameter description	Default value
Name	N bytes	Name (N • 248)	

- Mode

Event	header		Event parameter(s)
	ID	Size	
Mode	0x04	0x0001	Mode

Parameter	Size	Parameter description	Default value
Mode	1 byte	0x01 → Batch 0x02 → RealTime 0x03 → Lan	0x03 (Lan)

		0x04 → AutoSwitch	
--	--	-------------------	--

- Sniff

Event	header		Event parameter(s)
	ID	Size	
Sniff	0x10	0x0004	MinSniff, MaxSniff

Parameter	Size	Parameter description	Default value
MinSniff	2 bytes	Minimum interval, in slots, for sniff mode negotiation	0x0050 (80 slots)
MaxSniff	2 bytes	Maximum interval, in slots, for sniff mode negotiation	0x0320 (800 slots)

- Security Mode

Event	header		Event parameter(s)
	ID	Size	
Security Mode	0x20	0x0001	Security mode

Parameter	Size	Parameter description	Default value
Security mode	1 byte	0x00 → pin code off 0x01 → pin code on	0x01 (On)

- Link TMO

Event	header		Event parameter(s)
	ID	Size	
Link TMO	0x18	0x0002	Link TMO

Parameter	Size	Parameter description	Default value
Link TMO	2 bytes	Link time out	0x7D00 (32 slots)

- Remote BDA

Event	header		Event parameter(s)
	ID	Size	
Remote BDA	0x06	0x0006	Remote BDA

Parameter	Size	Parameter description
Remote BDA	6 bytes	Remote BDA used in master mode

- PageScan

Event	header		Event parameter(s)
	ID	Size	
PageScan	0x13	0x0004	Ps_Interval, Ps_Window

Parameter	Size	Parameter description	Default value
-----------	------	-----------------------	---------------

Ps_Interval	2 bytes	Page scan interval (between 0x0012 and 0x1000 slots)	0x0320 (800 slots)
Ps_Window	2 bytes	Page scan window (between 0x0012 and 0x1000 slots)	0x0090 (144 slots)

- InquiryScan

Event	header		Event parameter(s)
	ID	Size	
InquiryScan	0x15	0x0004	Is_Interval, Is_Window

Parameter	Size	Parameter description	Default value
Is_Interval	2 bytes	Inquiry scan interval (between 0x0012 and 0x1000 slots)	0x0640 (1600 slots)
Is_Window	2 bytes	Inquiry scan window (between 0x0012 and 0x1000 slots)	0x0018 (24 slots)

- Power

Event	header		Event parameter(s)
	ID	Size	
Power	0x39	0x0004	Def_Power, Max_Power

Parameter	Size	Parameter description
Def_Power	2 bytes	Default transmit power (in dBm)
Max_Power	2 bytes	Maximum transmit power (in dBm)

- Timers

Event	header		Event parameter(s)
	ID	Size	
Timers	0x54	0x0004	Tlisten, Tconnect

Parameter	Size	Parameter description	Default value
Tlisten	2 bytes	Timer used to shutdown the barcode reader when this later is not connected (resolution: second)	0x0258 (600 s)
Tconnect	2 bytes	Timer used to shutdown the barcode reader when this later is connected (resolution: minute)	0x0014 (20 m)

- Sending Format

Event	Header		Event parameter(s)
	ID	Size	
Sending Format	0x37	0x0003	Ack, Prefix/Suffix mode, Encapsulation mode

Parameter	Size	Parameter description	Default value
Ack	1 byte	0x00 → disable 0x001 → enable	0x00 (off)
Prefix/Suffix mode	1 byte	Add a prefix or/and a suffix 0x00 → disable	0x00 (off)

Encapsulation mode	1 byte	0x01 → enable	0x01 (on)
		Baracoda encapsulation mode 0x00 → disable 0x01 → enable	

- Prefix / Suffix

Event	Header		Event parameter(s)
	ID	Size	
Prefix / Suffix	0x35	N • 41	Prefix's size, Prefix, Suffix

Parameter	Size	Parameter description	Default value
Prefix's size	1 byte	Size of the prefix parameter {M byte(s)}	0x00
Prefix	M byte	Prefix character(s) (max: 20 characters)	None
Suffix	N – M - 1 bytes	Suffix character(s) (max: 20 characters)	None

Note:

If the prefix's size = 0, only a suffix is configured.
 If N = (prefix's size – 1), only a prefix is configured

The return is the hexadecimal value of a character. For example:

Event ID	Size	Prefix's size	Prefix		Suffix	
0x35	0x0006	0x01	0x34	0x31	0x35	0x38
			'4'	'1'	'5'	'8'

Prefix = 0x41 ('A') Suffix = 0x58 ('X')

- Versions

After having received the "Get_Versions" command, the scanner will reply in sending 2 different packets:

- First one: version of the SmartModule's firmware

Event	header		Event parameter(s)
	ID	Size	
Version	0x76	N	Version

Parameter	Size	Parameter description
Version	N bytes	SmartModule's version

- Second one: version of MPU's firmware

<SOH><CR><LF>Version BTxxx XX-XX-XXXX<EOT>

with :

BTxxx : 'xxx' is from 100 to 999

XX-XX-XXXX : date (ex : 02-26-2003)

2. Between the REMOTE APPLICATION and the MPU

2.1.Format of packet

To configure the MPU, the SmartModule must be in pipe mode (default mode). If you have previously broken the pipe to configure the SmartModule, you have to send the command “0x01 0x02 0x01” (see Introduction).

2.1.1. Single command

Header	Command	Footer
<SOH><CR><LF> 0x01 0x0d 0x0a	CMD	<EOT> 0x04

a. Multiple commands

Header	Command_1	Terminator	...	Command_N	Terminator	Footer
<SOH><CR><LF> 0x01 0x0d 0x0a	CMD_1	<CR><LF>	...	CMD_N	<CR><LF>	<EOT> 0x04

2.2.Remote application to the MPU

2.2.1. “General” commands

Command	Size (bytes)	Name	Return
NBG0	2	Set UserInterface_Decoded	None
NBG1	2	Set UserInterface_AckReceived	None
NBG2	0	Get UserInterface_Decoded	Beep/Led
NBG3	0	Get UserInterface_AckReceived	Beep/Led
NBG4	2	Set UserInterface_AckNack-NotReceived	None
NBG5	0	Get UserInterface_AckNack-NotReceived	Beep/Led
NBG6 (**)	2	Set UserInterface_NackReceived	None
NBG7 (**)	0	Get UserInterface_NackReceived	Beep/Led
NBG8 (**)	1	Set Nb_scan_without-RF-connection	None
NBG9 (**)	0	Get Nb_scan_without-RF-connection	Nb_scan (max : 32h)
WTN0	1	Set AckTimer	None
WTN1	0	Get AckTimer	
FS00	0	Get NbBarcodeStored	
UP00	0	Upload	
SM01 (*)	0	Set ScanTriggerMode	
SM02 (*)	0	Set ScanAutoMode	
SM03 (*)	0	Get ScanMode	

(*) : command is available on decoder, which has a version upper or equal to BT052

(**) : command is available on decoder, which has a version upper or equal to BT077

2.2.2. Details of “General” commands

- Set UserInterface Decoded

Command	Header	Command parameter(s)	Return parameter(s)
Set UserInterface Decoded	NBG0	NbBeep, NbLed	None

Parameter	Size	Parameter description
NbBeep	1	Number of beep when a barcode is scanned and decoded
NbLed	1	Number of green led flash when a barcode is scanned and decoded

- Set UserInterface AckReceived

Command	Header	Command parameter(s)	Return parameter(s)
Set UserInterface AckReceived	NBG1	NbBeep, NbLed	None

Parameter	Size	Parameter description
NbBeep	1	Number of beep when the acknowledgment is received.
NbLed	1	Number of green led flash when the acknowledgment is received.

- Set UserInterface AckNack-NotReceived

Command	Header	Command parameter(s)	Return parameter(s)
Set UserInterface AckNack-NotReceived	NBG4	NbBeep, NbLed	None

Parameter	Size	Parameter description
NbBeep	1	Number of beep when the acknowledgment is not received.
NbLed	1	Number of green led flash when the acknowledgment is not received.

- Set UserInterface NackReceived

Command	Header	Command parameter(s)	Return parameter(s)
Set UserInterface NackReceived	NBG6	NbBeep, NbLed	None

Parameter	Size	Parameter description
NbBeep	1	Number of beep when the acknowledgment is not received.
NbLed	1	Number of red led flash when the acknowledgment is not received.

Nota : This command is available on decoder, which has a version upper or equal to BT077

- Set Nb_Scan Without-RFconnection

Command	Header	Command parameter(s)	Return parameter(s)
Set Nb_Scan Without-RFconnection	NBG8	NbScan	None

Parameter	Size	Parameter description
NbScan	1	Number of scan that the scanner is allowed to scan when there is no RFconnection (in Real Time operating mode)

Nota : This command is available on decoder, which has a version upper or equal to BT077

- Set AckTimer

Command	Header	Command parameter(s)	Return parameter(s)
Set AckTimer	WTN0	Timer	None

Parameter	Size	Parameter description
Timer	1	Timer used for the acknowledgment (resolution: 0,1 s)

- Set ScanTriggerMode

Command	Header	Command parameter(s)	Return parameter(s)
Set ScanTriggerMode	SM01	None	None

- Set ScanAutoMode

Command	Header	Command parameter(s)	Return parameter(s)
Set ScanAutoMode	SM02	None	None

- Get ScanMode

Command	Header	Command parameter(s)	Return parameter(s)
Get ScanMode	SM03	None	ScanMode

Parameter	Size	Parameter description
ScanMode	1	0 : Trigger Mode 1 : Auto Scan Mode

Nota : This command is available on decoder, which has a version upper or equal to BT052

2.2.3. Commands to configure Symbologies

Command	Header	Command parameter(s)	Return parameter(s)
Get SymbConfig	PARA	None	SymbConfig

Parameter	Size	Parameter description
SymbConfig	27	See §2.3.c “Symbologies” commands

Symbology	Description	Command
Code 39	Code39 family enable (*)	RC01
	Code39 family disable	RD01
	Standard code39 (*)	3901
	Full ASCII code39 support	3902
	Code39 start/stop character transmission	3903
	Code39 start/stop character without transmission (*)	3904
	Code39 check digit calculate and transmit	3905
	Code 39 check digit calculate but without transmission	3906
	No check digit control (*)	3907
	Code 39 maximum length setting	3908xx
	Code 39 Minimum length setting	3909xx
	Code39 concatenation enable	3910
	Code39 concatenation disable (*)	3911
Code 32 (Italian Pharmacy)	Code 32 enable	RC13
	Code 32 disable (*)	RD13
	Transmit “A” character as header	3912
	Without transmit”A” character	3913
Interleave 2 of 5	ITF 2 of 5 code enable (*)	RC04
	ITF 2 of 5 code disable	RD04
	Maximum length setting	IT01xx
	Minimum length setting	IT02xx
	No check digit control (*)	IT03
	Check digit calculate and transmission	IT04
Check digit calculate but without transmission	IT05	
<p>xx = ASCII numbers that define the code length (00~32) (*) = default value</p> <p>Code length : The minimum code length has to be inferior than or equal to the maximum The maximum code length is :</p> <p style="text-align: right;">Code 39 : 32 Characters Code 32 : 32 Characters ITF 2of5 : 32 Characters</p>		

Symbology	Description	Command
Chinese Post	Chinese post code enable	RC05
	Chinese post code disable (*)	RD05
	Maximum length setting	SZ01xx
	Minimum length setting	SZ02xx
	No check digit control (*)	SZ03
	Check digit calculate and transmission	SZ04
	Check digit calculate but without transmission	SZ05
Codabar	Codabar enable (*)	RC02
	Codabar disable	RD02
	No start/stop character transmission	CB05
	Start/stop character transmission as A,B,C,D format (*)	CB06
	Start/stop character transmission as DC1~DC4 format	CB07
	Start/stop character transmission as a/t,b/n,c/*,d/e format	CB08
	Maximum length setting	CB09xx
	Minimum length setting	CB10xx
	Code128	Code 128 enable (*)
Code 128 disable		RD06
Code 128 FNC2 concatenation enable		1801
Code128 FNC2 concatenation disable (*)		1802
Enable EAN-128 FNC1 character transmitted		1810
Disable EAN-128 FNC1 character transmitted (*)		1811
Maximum length setting		1806xx
Minimum length setting		1807xx
Code 93	Code 93 enable (*)	RC08
	Code 93 disable	RD08
	Maximum length setting	9301xx
	Minimum length setting	9302xx
<p>xx = ASCII numbers that define the code length (00~32) (*) = default value</p> <p>Code length : The minimum code length has to be inferior than or equal to the maximum The maximum code length is :</p> <p style="text-align: right;">Chinese post code : 32 Characters Codabar code : 56 Characters Code 128 : 62 Characters Code 93 : 32 Characters</p>		

Symbology	Description	Command
UPC / EAN	UPC/EAN family enable (*)	RC03
	UPC/EAN family disable	RD03
	EAN-13 convert to ISSN/ISBN enable	RC11
	EAN-13 convert to ISSN/ISBN disable (*)	RD11
	Enable UPC-A,UPC-E,EAN-13,EAN-8 (*)	UE01
	Only enable EAN-8 and EAN-13	UE02
	Only enable UPC-A and EAN-13	UE03
	Only enable UPC-A and UPC-E	UE04
	Only enable UPC-A	UE05
	Only enable UPC-E	UE06
	Only enable EAN-13	UE07
	Only enable EAN-8	UE08
	UPC/EAN addendum code off (*)	UE09
	UPC/EAN with 5 characters addendum	UE10
	UPC/EAN with 2 characters addendum	UE11
	UPC/EAN with 2 or 5 characters addendum	UE12
	Force UPC-E to UPC-A format enable	UE13
	Force UPC-E to UPC-A format disable (*)	UE14
	Force UPC-A to EAN-13 format enable	UE15
	Force UPC-A to EAN-13 format disable (*)	UE16
	Transmit UPC-A check digit (*)	UE17
	Without Transmit UPC-A check digit	UE18
	Transmitted UPC-E leading character (*)	UE19
	Without transmit UPC-E leading character	UE20
	Transmitted UPC-E check digit (*)	UE21
	Without transmit UPC-E check digit	UE22
	Transmitted EAN-8 check digit (*)	UE23
	Without transmit EAN-8 check digit (*)	UE24
Transmitted EAN-13 check digit (*)	UE25	
Without transmit EAN-13 check digit	UE26	
Transmit UPC-A leading character (*)	UE27	
Without transmit UPC-A leading character	UE28	
(*) = default value		

Symbology	Description	Command
MSI / PLESSY (**)	MSI/PLESSY enable	RC14
	MSI/PLESSY disable (*)	RD14
	Maximum length setting	MS01xx
	Minimum length setting	MS02xx
	MSI/PLESSY double check digit calculate but not transmitted (*)	MS03
	MSI/PLESSY double check digit calculate but only first digit transmitted	MS05
	MSI/PLESSY double check digit calculate and both transmitted	MS06
	MSI/PLESSY single check digit calculate but not transmitted	MS07
	MSI/PLESSY single check digit calculate and transmitted	MS08
Industry 25 Code (**)	Industry 25 enable	RC07
	Industry 25 disable (*)	RD07
	Industry 25 Maximum length setting	ID01xx
	Industry 25 Minimum length setting	ID02xx
EAN-128	EAN-128 enable	RC10
	EAN-128 disable (*)	RD10
IATA Code (**)	IATA enable	RC09
	IATA disable (*)	RD09
<p>xx = ASCII numbers that define the code length (00~32) (*) = default value</p> <p>Code length : The minimum code length has to be inferior than or equal to the maximum The maximum code length is :</p> <p style="text-align: right;">MSI/PLESSY : 62 Characters Industry 25 : 32 Characters</p>		

(**) : command is available on decoder, which has a version upper or equal to BT063

2.3.MPU to remote application

2.3.1. “Normal” events

Event ID	Size (bytes)	Name
0x32	N	Barcode (no ack) (see §3. Details of a sending of barcodes)
0x33	N	Barcode (with ack) (see §3. Details of a sending of barcodes)

2.3.2. “General” commands events

Name	Size (bytes)	Parameters
Beep/Led	2	Nb_Beep, Nb_Led
AckTimer	1	Timer (resolution: 0,1 s)
NbStoredBarcode	4	Nb_Barcodes
Barcode	N	Barcode (without encapsulation) (see §3. Details of a sending of barcodes)
ScanMode (*)	1	0x00 : Trigger mode 0x01 : Auto scan mode

(*) : command is available on decoder, which has a version upper than BT052

2.3.3. “Symbologies” commands event

Description of the SymbConfig event				
Byte		Bit		Description
Number	Description	Number	Value	
0	EAN	0	1	Read EAN-13 enable
			0	Read EAN-13 disable
		1	1	Read EAN-8 enable
			0	Read EAN-8 disable
		2	1	Read EAN Add 2 enable
			0	Read EAN Add 2 disable
		3	1	Read EAN Add 5 enable
			0	Read EAN Add 5 disable
		4		Not defined
		5	1	Send EAN-13 Check digit
			0	Not Send EAN-13 Check digit
		6		Not defined
		7	1	Send EAN-8 Check digit
			0	Not Send EAN-8 Check digit
		0	1	Read UPC-A enable
			0	Read UPC-A disable
		1	1	Read UPC-E enable
			0	Read UPC-E disable
		2	1	Read UPC Add 2 enable

1	UPC		0	Read UPC Add 2 disable	
		3	1	Read UPC Add 5 enable	
			0	Read UPC Add 5 disable	
		4	1	Send UPC-A Leading 0	
			0	Not send UPC-A Leading 0	
		5	1	Send UPC-A Check digit	
			0	Not send UPC-A Check digit	
		6	1	Send UPC-E Leading 0	
			0	Not send UPC-E Leading 0	
		7	1	Send UPC-E Check digit	
			0	Not send UPC-E Check digit	
		2	0		Not defined
			1	1	UPC-E to UPC-A enable
				0	UPC-E to UPC-A disable
2 to 3			Not defined		
4	1		ISBN/ISSN conversion enable		
	0		ISBN/ISSN conversion disable		
5 to 7		Not defined			

Byte		Bit		Description
Number	Description	Number	Value	
3	Code 39	0	1	Read Code 39 enable
			0	Read Code 39 disable
		1	1	Send Start/Stop character
			0	Not send Start/Stop character
		2	1	Check digit verification enable
			0	Check digit verification disable
		3	1	Send Check digit
			0	Not Send Check digit
		4	1	Full Code 39 disable
			0	Full Code 39 enable
		5	1	Code 32 conversion enable
			0	Code 32 conversion disable
		6	1	Code 32 Transmit "A" character enable
			0	Code 32 Transmit "A" character disable
7	1	Code 39 concatenation enable		
	0	Code 39 concatenation disable		
4			Minimum code length	
5			Maximum code length	
6	Codabar	0	1	Read Codabar enable
			0	Read Codabar disable
		1	1	Send Start/Stop character
			0	Not send Start/Stop character
		2	1	Send Check digit
			0	Not Send Check digit
		3	1	Check digit verification enable
			0	Check digit verification disable
		4 to 7	0x06 h	ST/SP = ABCD / ABCD
			0x07 h	ST/SP = DC1 to DC4 / DC1 to DC4
0x08 h	ST/SP=abcd/tn*e			
7			Minimum code length	
8			Maximum code length	
9	Interleave 2 of 5	0	1	Read Interleave 2 of 5 enable
			0	Read Interleave 2 of 5 disable
		1 to 5		Not defined
		6	1	Send Check digit
			0	Not Send Check digit
		7	1	Check digit verification enable
0	Check digit verification disable			
10			Minimum code length	
11			Maximum code length	

Byte		Bit		Description	
Number	Description	Number	Value		
12	Code 128	0	1	Read Code 128 enable	
			0	Read Code 128 disable	
		1	1	Read EAN-128 enable	
			0	Read EAN-128 disable	
		2 to 3		Not defined	
		4	1	Code 128 FNC2 concatenation enable	
			0	Code 128 FNC2 concatenation disable	
		5	1	EAN 128 FNC1 character transmitted enable	
			0	EAN 128 FNC1 character transmitted disable	
		6 to 7		Not defined	
13			Minimum code length		
14			Maximum code length		
15	Code 93	1	1	Read Code 93 enable	
			0	Read Code 93 disable	
		2	1	Send Start/Stop character	
			0	Not send Start/Stop character	
		3	1	Check digit verification enable	
			0	Check digit verification disable	
		4	1	Full code 93 disable	
			0	Full code 93 enable	
		5 to 7		Not defined	
		16			Minimum code length
17			Maximum code length		
18	Chinese Post	1	1	Chinese Post 25 enable	
			0	Chinese Post 25 disable	
		1 to 5		Not defined	
		6	1	Send Check digit	
			0	Not Send Check digit	
		7	1	Check digit verification enable	
			0	Check digit verification disable	
		19		1	Minimum code length
		20		0	Maximum code length
		21	MSI (*)	0	1
0	Read Code MSI disable				
1 & 2	00			Not Send Check digit(s)	
	01			Send single check digit	
	10			Calculation 2 check digits & sending of the 1st one	
	11			Send both Check digits	
3 & 4	00			Double or single module 10 check digit disable	
	10			Single module 10 check digit enable	
	11			Double module 10 check digit enable	
5 to 7				Not defined	
22			Minimum code length		
23			Maximum code length		

(*) : command is available on decoder, which has a version upper than BT063

Byte		Bit		Description
Number	Description	Number	Value	
24	IATA (*)	0	1	Read IATA enable
			0	Read IATA disable
		1 to 7		Not defined
25	Industry 2 of 5 (*)	0	1	Read Industry 2 of 5 enable
			0	Read Industry 2 of 5 disable
		1 to 7		Not defined
26				Minimum code length
27				Maximum code length

(*) : command is available on decoder, which has a version upper than BT063

3. DETAILS OF A SENDING OF BARCODES

3.1.Possibilities

This paragraph is describing the format of packets, which are sent from the barcode scanner to the remote application after having scanned a barcode.

There are 9 possibilities to receive a scanned barcode:

Ack	Pref/ Suff	Baracoda encap	Example												
OFF	OFF	OFF	<table border="1" style="margin: auto;"> <tr> <td style="padding: 2px;">Barcode</td> </tr> <tr> <td style="text-align: center;">N bytes</td> </tr> </table>	Barcode	N bytes										
Barcode															
N bytes															
ON	OFF	OFF	<table border="1" style="margin: auto;"> <tr> <td style="padding: 2px;">Barcode</td> </tr> <tr> <td style="text-align: center;">N bytes</td> </tr> </table>	Barcode	N bytes										
Barcode															
N bytes															
OFF	ON	OFF	<table border="1" style="margin: auto;"> <tr> <td style="padding: 2px;">Prefix</td> <td style="padding: 2px;">Barcode</td> <td style="padding: 2px;">Suffix</td> </tr> <tr> <td style="text-align: center;">M bytes</td> <td style="text-align: center;">N bytes</td> <td style="text-align: center;">P bytes</td> </tr> </table>	Prefix	Barcode	Suffix	M bytes	N bytes	P bytes						
Prefix	Barcode	Suffix													
M bytes	N bytes	P bytes													
OFF	OFF	ON	<table border="1" style="margin: auto;"> <tr> <td style="padding: 2px;">0x32</td> <td style="padding: 2px;">Size</td> <td style="padding: 2px;">Barcode</td> </tr> <tr> <td style="text-align: center;">1 byte</td> <td style="text-align: center;">2 bytes</td> <td style="text-align: center;">N bytes (= size)</td> </tr> </table>	0x32	Size	Barcode	1 byte	2 bytes	N bytes (= size)						
0x32	Size	Barcode													
1 byte	2 bytes	N bytes (= size)													
ON	OFF	ON	<table border="1" style="margin: auto;"> <tr> <td style="padding: 2px;">0x33</td> <td style="padding: 2px;">Size</td> <td style="padding: 2px;">ID</td> <td style="padding: 2px;">Barcode</td> </tr> <tr> <td style="text-align: center;">1 byte</td> <td style="text-align: center;">2 bytes</td> <td style="text-align: center;">1 byte</td> <td style="text-align: center;">N bytes (= size - 1)</td> </tr> </table>	0x33	Size	ID	Barcode	1 byte	2 bytes	1 byte	N bytes (= size - 1)				
0x33	Size	ID	Barcode												
1 byte	2 bytes	1 byte	N bytes (= size - 1)												
ON	ON	OFF	<table border="1" style="margin: auto;"> <tr> <td style="padding: 2px;">Prefix</td> <td style="padding: 2px;">Barcode</td> <td style="padding: 2px;">Suffix</td> </tr> <tr> <td style="text-align: center;">M bytes</td> <td style="text-align: center;">N bytes</td> <td style="text-align: center;">P bytes</td> </tr> </table>	Prefix	Barcode	Suffix	M bytes	N bytes	P bytes						
Prefix	Barcode	Suffix													
M bytes	N bytes	P bytes													
OFF	ON	ON	<table border="1" style="margin: auto;"> <tr> <td style="padding: 2px;">0x32</td> <td style="padding: 2px;">Size</td> <td style="padding: 2px;">Prefix</td> <td style="padding: 2px;">Barcode</td> <td style="padding: 2px;">Suffix</td> </tr> <tr> <td style="text-align: center;">1 byte</td> <td style="text-align: center;">2 bytes</td> <td style="text-align: center;">M bytes</td> <td style="text-align: center;">N bytes</td> <td style="text-align: center;">P bytes</td> </tr> </table>	0x32	Size	Prefix	Barcode	Suffix	1 byte	2 bytes	M bytes	N bytes	P bytes		
0x32	Size	Prefix	Barcode	Suffix											
1 byte	2 bytes	M bytes	N bytes	P bytes											
ON	ON	ON	<table border="1" style="margin: auto;"> <tr> <td style="padding: 2px;">0x33</td> <td style="padding: 2px;">Size</td> <td style="padding: 2px;">ID</td> <td style="padding: 2px;">Prefix</td> <td style="padding: 2px;">Barcode</td> <td style="padding: 2px;">Suffix</td> </tr> <tr> <td style="text-align: center;">1 byte</td> <td style="text-align: center;">2 bytes</td> <td style="text-align: center;">1 byte</td> <td style="text-align: center;">M bytes</td> <td style="text-align: center;">N bytes</td> <td style="text-align: center;">P bytes</td> </tr> </table>	0x33	Size	ID	Prefix	Barcode	Suffix	1 byte	2 bytes	1 byte	M bytes	N bytes	P bytes
0x33	Size	ID	Prefix	Barcode	Suffix										
1 byte	2 bytes	1 byte	M bytes	N bytes	P bytes										

3.2.Management of acknowledgment

All barcodes sent by the barcode reader to the remote application, which have header '0x33' needs to be acknowledged before to be deleted. So, after a sending of data, the barcode reader

has to wait for a `BARCODE_ACK` from the host (remote application) to send the next scanned barcode.

When a `BARCODE_ACK` is received, the data is deleted (from the RAM of the MPU).

If nothing is received, the next barcode will be sent after having received the acknowledgment of the previous one.

For the next scanned barcode, the scanner will try to send again the first barcode of the buffer in following the previous process. (i.e: first in, first out)

3.2.1. Barcode ACK command format

Command	Header	Command parameter(s)	Return parameter(s)
<code>BARCODE_ACK</code>	<code>0x06 0x01</code>	Barcode ID	None

Parameter	Size	Parameter description
Barcode ID	1	Barcode ID

In order to send an acknowledgement, the SmartModule must be in pipe mode. If you have previously broke the pipe in order to configure the SmartModule, send the command "`0x01 0x02 0x01`" (see Introduction).

3.2.2. Examples

The following paragraph explains the sending of a barcode with specific encapsulation and the acknowledgement.

- Success of acknowledge

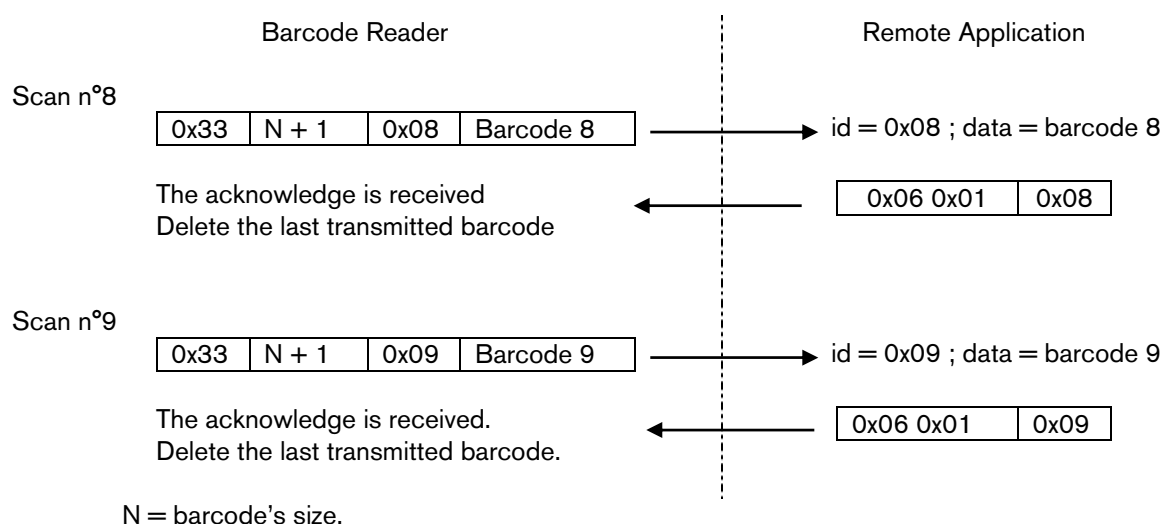

- Failure of sending



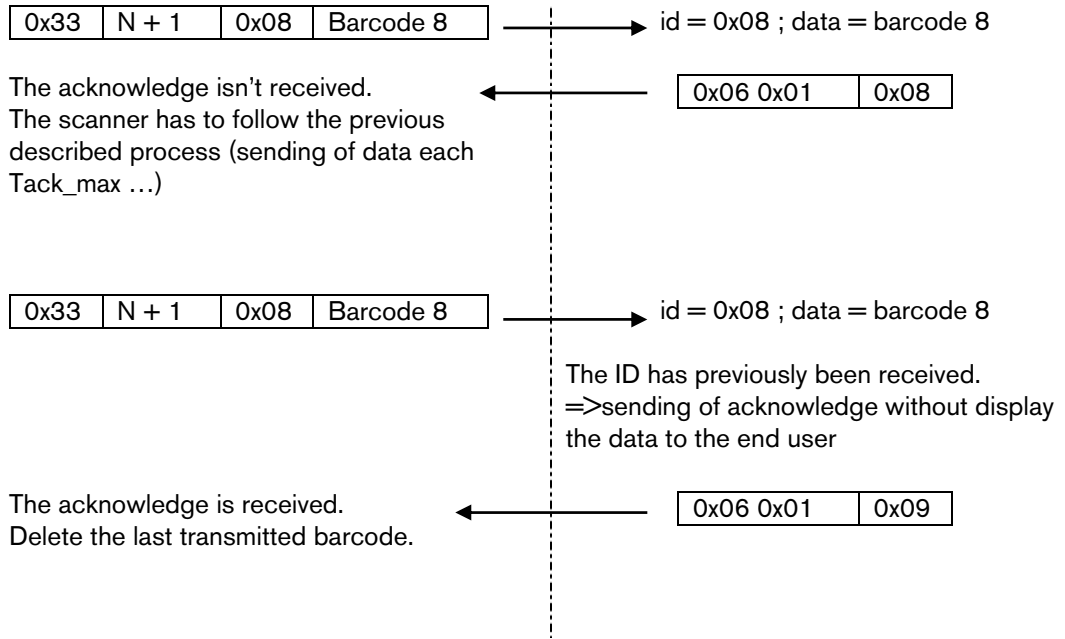

N = barcode's size.

4. DEFAULT SETTINGS

4.1. Smartmodule

Parameter	Default value	Meaning
Pin code	0x30 0x30 0x30 0x30	'0000'
Mode	0x03	Lan
MinSniff	0x0050	80 slots
MaxSniff	0x00F0	240 slots
Security Mode	0x01	Pin Code enabled
Link TMO	0x7D00	32 000 slots
Tlisten	0x0258	10 min
Tconnect	0x0014	20 min
SendingFormat	0x00 0x00 0x01	Ack → off Prefix/Suffix → off Baracoda encapsulation → on
Prefix	0x00	None
Suffix	0x00	None
PageScan	0x0320 0x0090	Interval = 800 slots Window = 144 slots
InquiryScan	0x0640 0x0018	Interval = 1600 slots Window = 20 slots

Nota : 1 slot = 0,625 ms

4.2.Decoder

Function	Code	Default value
Reading codes selection	Code 39	Enable
	Interleave 2 of 5	Enable
	Chinese Post code	Disable
	UPC / EAN / JAN	Enable
	Codabar	Enable
	Code 128	Enable
	Code 93	Enable
	EAN 128	Disable
	Italian Pharmacy	Disable
	ISSN / ISBN	Disable
	IATA code (*)	Disable
	MSI / PLESSY (*)	Disable
	Industry 2 of 5 (*)	Disable
Code 39	Codes	Standard
	Start / Stop characters	Not transmitted
	Check digit	Disable
	Concatenation	Disable
Interleave 2 of 5	Length	6 ~ 32 digits
	Check digit	Disable
Chinese Post Code	Length	8 ~ 32 digits
	Check digit	Disable
UPC / EAN / JAN	Format	All
	Addendum	Disable
	UPC-E = UPC-A	Disable
	UPC-A = EAN13	Disable
	UPC-A leading digit	Transmit
	UPC-A check digit	Transmit
	UPC-E leading digit	Transmit
	UPC-E check digit	Transmit
	EAN-8 check digit	Transmit
EAN-13 check digit	Transmit	
Codabar	Start / Stop characters	A, B, C, D
	Length	6 ~ 56 digits
Code 128	FNC 2 concatenation	Disable
	EAN-128 FNC1	Not Transmit
Code 93	Length	3 ~ 32 digits
Italian Pharmacy	Transmit "A" character	Not transmitted
MSI / PLESSY (*)	Length	3 ~ 32 digits
	Check digit	Double check but not transmitted
Industry 2 of 5 (*)	Length	6 ~ 32 digits

(*) : command is available on decoder, which has a version upper than BT063